



P etroPompSad

Pump Technologies | Pompa Teknolojile

Ex Proof Motors Series





EX-PROOF MOTORS





Both of the power rating and installation size of the motor are comply with the international electrotechnical commission (IEC) standards. And corresponding relation same as the YB series, so they can swap with YB motor.

MODEL SPECIFICATION

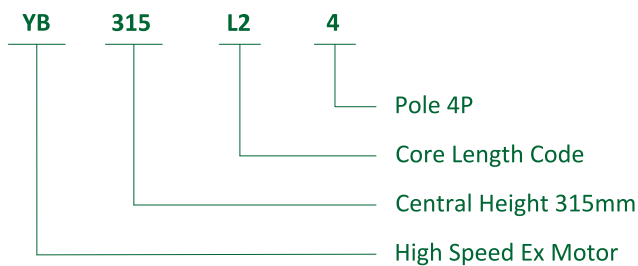

WORK CONDITIONS

- Rated Voltage : 380V, 660V, 380/660V,, 660/1140V
- Output Power : 0,18 kW -315 kW
- Poles : 2-8
- Protection Class : IP55
- Insulation Class : F,H Temperature Rise B
- Altitude : Not Exceed 1000 meters
- Rated Frequency : 50 Hz
- Duty : Continuous (S1)
- Ambient Temperature : -15°C / +40°C
- Ex-Mark : "Exd I" or "Exd II", Exd II Ct4"

DANGEROUS AREAS

The dangerous enviroments are classified into zones, show in the following scheme;

Gas	Dust	Presence Of Potentially Explosive Atmosphere
Zone 0	Zone 20	Always present, frequent or lasting long periods during normal operation. The use of electric motors is not allowed.
Zone 1	Zone 21	Incidental presence: likely to occur during normal operationn of the equipment.
Zone 2	Zone 22	Accidental presence: unlikely to occur during normal operation of the equipment.

GROUPS

The electrical apparatus is subdivided into two **groups** (EN 50014), according to the environments in which the equipment will operate.

Group	I	II
Environment	Used in subterranean mines and on the surface of mines in the presence of grisou and / or combustible dust.	Explosive atmospheres other than mines; surface industries.

CATEGORIES

Each group is classified into **categories**, according to the level of protection the apparatus must have;

Group I	Category	M1	M2
	Level of Protection	Very high	High
	In the presence of explosive atmosphere	The apparatus must remain operative	The electrical supply to the equipment must be interrupted

Group II	Category	1	2	3
	Level of Protection	Very high	High	Normal
	Presence of explosive atmosphere	High probability (always, often, for extended periods)	Probable	Low probability (rare and for a short time)
	Zones in which the equipment may be fed and may operate	0, 1, 2 and / or 20, 21, 22	Only 1, 2 and / or 21, 22	Only 2 and / or 22

The equipment belonging to group II is also specified by the nature of the atmosphere and can be arranged into the following categories:

G = mixture of air and gas, vapour or mist

D = mixture of air and combustible dust

Gas atmospheres are further divide into three sub-groups, according to the nature of the gas:

Group	Examples of some substances
II A	acetone, acetic acid, methanol, ethanol, benzene, ethane, methane, propane, toluene, xylene, combustible oil, kerosene, acetaldehyde ethylbenzene, isoprene
II B	coke-oven gas, ethylene, ethylene oxide, ethyl ether, formic aldehyde
II C	hydrogen, acetylene, water gas, carbon sulphur

A motor belonging to a particular group is also suitable for use in a lower group (e.g. a motor used in group IIB is also suitable for group IIA).

TYPES OF PROTECTION

The EN 60079-10 standard classifies the dangerous areas, while the standard EN 60079-14 defines the compatibility between the protection method with the aforementioned dangerous zones. The types of protection are defined as follows:

For mixtures of air and-gas, vapour or fog	For mixtures of air and dust
"d" - Flameproof enclosures (EN 50118)	IP y + maximum permitted surface temperature (y=6 category 2D; y=5 category 3D.) Electrical apparatus intended for use in environments with the presence of combustible dust. (EN 50281-1-1). When only this method of protection is requested, it is not necessary for the motors to be explosion proof,, but in addition to the grade of protection mentioned above, they must have a maximum surface temperature limited to a specified value.
"e" - Increased (EN 50019)	
"n" - in accordance with standad (EN 50021)	

TEMPERATURE CLASS

See definition on page 4: "Maximum surface temperature".

DEGREE OF PROTECTION IP55

Motors of Category 2G operating at a maximum ambient temperature of 40°C can be supplied with IP55 protection degree under the following temperature class:

- 2 pole motors: temperature class T3
- ≥ 4 pole motors: temperature calss T3, T4

DEFINITIONS

The present catalogue lists motors for use in potentially explosive atmosphere, relative to:

- Group I Category M2, for motor sizes 160-315
- Group II Category 2G, 2D.

EXPLOSIVE ATMOSPHERE

Is a mixture of flammable substances in the state of gas, vapour, mist and dust:

- with air
- in which, after ignition, applies to products for use in this environment.

POTENTIALLY EXPLOSIVE ATMOSPHERE

It is an atmosphere which could become explosive either as a result of local and / or operating environmental conditions

TYPE OF PROTECTION "d"

The electrical equipment has an enclosure suitable to:

- resist the internal pressure from the ignition of an explosive mixture the equipment.
- avoid the transmission of the explosion to the external atmosphere in which the equipment is begin used.
- Ensure that the maximum external surface temperature is maintained within the limits specified by the temperature class of the equipment.

TYPE OF PROTECTION - INCREASED SAFETY "e"

A type of protection in which additional measures are applied so as to give increased security against the possibility of

- excessive temperature,
- the occurrence of arcs and sparks both inside and on external parts of electrical apparatus which does not produce arcs or sparks in normal service.

COMBINED TYPE OF PROTECTION - "de"

Combines the essential requirements of protection types "d" and "e" (in accordance with standards EN 50018 and EN 50019) specifically:

- motor enclosures with protection "d" (in accordance with standard EN50018);
- terminal boxes with increased safety "e" (in accordance with standard EN50019).

COMBINED CATEGORY 2G/2D

Combines the essential safety requirements:

- of protection type "d" (in accordance with standard EN50018)
- of the protection mode for electrical apparatus intended for use in environments with the presence of combustible dust, protection degree IP65 (EN50281.1.1).

MAXIMUM SURFACE TEMPERATURE

It is the maximum operating temperature reached in the most unfavourable conditions (but within relative limits) on the surface of electrical apparatus.

For equipment of group I, the maximum surface temperature must not exceed 150°C.

The following table is relevant to apparatus of category 2G, which is based on a predetermined temperature classification:

Temperature class	T1	T2	T3	T4	T5	T6
Maximum Surface Temperature (°C)	450	300	200	135	100	85

The maximum surface temperature is meant to be:

- the temperature of the external surfaces, for motors with protection mode "d",
- the temperature of the external surfaces and of the internal points of the terminal box, for motors with protection mode "de"

In a potentially explosive atmosphere, the maximum surface temperature of the equipment must remain lower the lowest possible spontaneous ignition temperature of the atmosphere surrounding it.

Electrical apparatus of category 2D are classified based the on maximum surface temperature. This catalogue applies to motors having either of the following three maximum surface temperatures: T 150°C, T 135°C and T 100°C. In the case of atmospheres with combustible dust, the maximum permitted surface temperature depends on: the type of dust, the thickness of the layer of dust and on a safety factor used according to (EN 50281-1-2).

Motors of category 2G can also be used in installations requiring apparatus in category 3G, provided that they comply with the specified temperature class. Likewise, category 2D motors can be used in category 3D installations requiring the same higher maximum surface temperature.

TECHNICAL DATA (50HZ)

Frame	Output (kW)		Rated Current			Speed r/min	Eff % η	Power Factor	Rated Torque	Locked Rotor	Max. Torque	Locked Rotor	Weight
	kW	HP	380V	400V	415V				T _n (Nm)	T _{st} / -T _n	T _{max} / T _n	T _{st} / I _n	
Synchronous Speed 3000 rpm													
YB-80M1-2	0,75	1	1,8	1,7	1,6	2875	77,4	0,83	2,5	2,2	2,3	6	24
YB-80M2-2	1,1	1,5	2,5	2,4	2,3	2875	79,6	0,84	3,7	2,2	2,3	6	25
YB-90S-2	1,5	2	3,3	3,2	3	2890	81,3	0,84	5	2,2	2,3	7	35
YB-90L-2	2,2	3	4,7	4,5	4,3	2890	83,2	0,85	7,4	2,2	2,3	7	38
YB-100L-2	3	4	6,2	5,9	5,7	2891	84,6	0,87	10	2,2	2,3	7	44
YB-112M-2	4	5,5	8	7,6	7,4	2914	85,8	0,88	13,3	2,2	2,3	7	46
YB-132S1-2	5,5	7,5	11,2	10,6	10,2	2918	87	0,88	18,1	2,2	2,3	7,5	81
YB-132S2-2	7,5	10	14,6	13,9	13,4	2920	88,1	0,88	24,7	2,2	2,4	7,5	89
YB-160M1-2	11	15	21	20	19,2	2930	89,4	0,89	35,9	2,2	2,4	7,5	142
YB-160M2-2	15	20	28,4	26,9	26	2930	90,3	0,89	48,9	2,2	2,4	7,5	152
YB-180M-2	18,5	25	34,7	33	31,8	2937	90,9	0,89	60,3	2,2	2,4	7,5	169
YB-180L-2	22	30	41,6	39,5	38,1	2940	91,3	0,89	71,5	2	2,3	7,5	227
YB-200L1-2	30	40	56,2	53,4	51,5	2950	92	0,88	97,1	2	2,4	7,5	265
YB-200L2-2	37	50	68,2	64,8	62,5	2950	92,5	0,89	120	2	2,4	7,5	275
YB-225M-2	45	60	82,5	78,4	75,6	2960	92,9	0,89	145	2	2,3	7,6	340
YB-250M-2	55	75	99,5	94,8	91,1	2965	93,2	0,9	177	2,1	2,3	7,6	477
YB-280S-2	75	100	135	128	123	2970	93,8	0,9	241	2	2,3	7,5	655
YB-280M-2	90	120	160	152	146	2970	94,1	0,91	289	2,1	2,3	7,5	733
YB-315S-2	110	150	194	185	178	2970	94,3	0,91	353	1,8	2,3	7	1140
YB-315M-2	132	180	233	221	213	2975	94,6	0,91	424	1,8	2,3	7	1170
YB-315L1-2	160	220	278	265	255	2975	94,8	0,92	514	1,8	2,3	7	1385
YB-315L2-2	200	270	348	330	318	2975	95	0,92	642	1,8	2,3	7	1610
YB-355M1-2	220	300	383	364	351	2985	95	0,92	704	1,6	2,4	7	1680
YB-355M2-2	250	340	434	412	398	2980	95	0,92	801	1,6	2,4	7	1720
YB-355L1-2	280	380	485	461	444	2985	95	0,92	896	1,6	2,4	7	1780
YB-355L2-2	315	430	547	520	501	2980	95	0,92	1010	1,6	2,4	7	1850

Safe and efficient motor solution providers and manufactures.

TECHNICAL DATA (50HZ)

Frame	Output (kW)		Rated Current			Speed r/min	Eff % η	Power Factor	Rated Torque	Locked Rotor	Max. Torque	Locked Rotor	Weight
	kW	HP	380V	400V	415V				T _n (Nm)	T _{st} / -T _n	T _{max} / T _n	T _{st} / I _n	
Synchronous Speed 1500 rpm													
YB-80M1-4	0,55	0,75	1,5	1,4	1,3	1390	75	0,75	3,8	2,3	2,3	6,3	24
YB-80M2-4	0,75	1	1,9	1,8	1,7	1400	79,6	0,76	5,2	2,3	2,3	6	27
YB-90S-4	1,1	1,5	2,7	2,5	2,4	1440	81,4	0,75	7,5	2,3	2,3	6	34
YB-90L-4	1,5	2	3,6	3,4	3,3	1445	82,8	0,75	10,2	2,3	2,3	6	38
YB-100L1-4	2,2	3	4,9	4,6	4,5	1440	84,3	0,81	14,8	2,3	2,3	7	46
YB-100L2-4	3	4	6,5	6,2	6	1440	85,5	0,82	20,2	2,3	2,3	7	51
YB-112M-4	4	5,5	8,6	8,1	7,8	1445	86,6	0,82	26,5	2,3	2,3	7	68
YB-132S-4	5,5	7,5	11,5	10,9	10,5	1445	87,7	0,82	36,5	2,3	2,3	7	85
YB-132M-4	7,5	10	15,3	14,5	14	1445	88,7	0,83	49,7	2,3	2,3	7	105
YB-160M-4	11	15	22,1	21	20,3	1460	89,8	0,85	72	2,2	2,3	7	150
YB-160L-4	15	20	29,6	28,1	27,1	1460	90,6	0,86	98,1	2,2	2,3	7,5	171
YB-180M-4	18,5	25	35,8	34	32,8	1470	91,2	0,86	121	2,2	2,3	7,5	211
YB-180L-4	22	30	42,3	40,2	38,8	1470	91,6	0,86	143	2,2	2,3	7,5	224
YB-200L-4	30	40	57,3	54,4	52,5	1470	92,3	0,86	195	2,2	2,3	7,2	290
YB-225S-4	37	50	69,7	66,2	63,8	1480	92,7	0,86	240	2,2	2,3	7,2	346
YB-225M-4	45	60	84,3	80,1	77,2	1480	93,1	0,86	291	2,2	2,3	7,2	358
YB-250M-4	55	75	103	97,5	94	1480	93,5	0,86	356	2,2	2,3	7,2	492
YB-280S-4	75	100	139	132	127	1480	94	0,88	484	2,2	2,3	7,2	670
YB-280M-4	90	120	167	158	153	1480	94,2	0,88	581	2,2	2,3	6,9	743
YB-315S-4	110	150	201	191	184	1485	94,5	0,88	710	2,1	2,2	6,9	986
YB-315M-4	132	180	241	229	220	1485	94,7	0,88	852	2,1	2,2	6,9	1070
YB-315L1-4	160	220	288	273	263	1485	94,9	0,89	1032	2,1	2,2	6,9	1350
YB-315L2-4	200	270	359	341	328	1485	95,1	0,89	1291	2,1	2,2	6,9	1572
YB-355M1-4	220	300	390	371	357	1490	95,1	0,9	1410	2,1	2,2	6,9	1690
YB-355M2-4	250	340	443	421	406	1490	95,1	0,9	1602	2,1	2,2	6,9	1750
YB-355L1-4	280	380	495	470	453	1490	95,1	0,9	1795	2,1	2,2	6,9	1800
YB-355L2-4	315	430	559	531	511	1490	95,1	0,9	2019	2,1	2,2	6,9	1850

TECHNICAL DATA (50HZ)

Frame	Output (kW)		Rated Current			Speed r/min	Eff % η	Power Factor	Rated Torque	Locked Rotor	Max. Torque	Locked Rotor	Weight
	kW	HP	380V	400V	415V				T _n (Nm)	T _{st} / -T _n	T _{max} / T _n	T _{st} / I _n	
Synchronous Speed 1000 rpm													
YB-80M1-6	0,37	0,5	1,3	1,2	0,7	910	63	0,7	3,9	1,9	2,1	4	20
YB-80M2-6	0,55	0,75	1,5	1,4	0,9	910	75,4	0,72	5,8	1,9	2,1	4	25
YB-90S-6	0,75	1	2,1	2	1,9	934	75,9	0,72	7,7	2	2,1	5,5	39
YB-90L-6	1,1	1,5	3	2,8	2,7	945	78,1	0,72	11,1	2	2,1	5,5	41
YB-100L-6	1,5	2	3,8	3,6	3,5	960	79,8	0,75	15,2	2	2,1	5,5	45
YB-112M-6	2,2	3	5,4	5,1	4,9	964	81,8	0,76	21,9	2	2,1	6,5	57
YB-132S-6	3	4	7,2	6,8	6,6	965	83,3	0,76	29,7	2,1	2,1	6,5	84
YB-132M1-6	4	5,5	9,4	9	8,6	965	84,6	0,76	39,6	2,1	2,1	6,5	92
YB-132M2-6	5,5	7,5	12,6	12	11,5	970	86	0,76	54,4	2,1	2,1	6,5	104
YB-160M-6	7,5	10	16,7	15,9	15,3	970	87,2	0,77	73,8	2	2,1	6,5	171
YB-160L-6	11	15	24,8	23,5	22,7	975	88,7	0,78	108	2	2,1	6,5	180
YB-180L-6	15	20	31,4	29,8	28,7	980	89,7	0,81	147	2	2,1	7	230
YB-200L1-6	18,5	25	38,3	36,4	35,1	980	90,4	0,81	180	2,1	2,1	7	309
YB-200L2-6	22	30	44,3	42	40,5	980	90,9	0,83	214	2,1	2,1	7	320
YB-225M-6	30	40	59,2	56,2	54,2	980	91,7	0,84	292	2	2,1	7	364
YB-250M-6	37	50	70,8	67,3	64,8	980	92,2	0,86	361	2,1	2,1	7	535
YB-280S-6	45	60	85,8	81,5	78,5	980	92,7	0,86	439	2,1	2	7	643
YB-280M-6	55	75	104	99,2	95,6	980	93,1	0,86	536	2,1	2	7	735
YB-315S-6	75	100	141	134	129	985	93,7	0,86	727	2	2	7	1095
YB-315M-6	90	120	169	160	155	985	94	0,86	873	2	2	7	1153
YB-315L1-6	110	150	206	196	189	985	94,3	0,86	1066	2	2	6,7	1330
YB-315L2-6	132	180	243	231	223	985	94,6	0,87	1280	2	2	6,7	1485
YB-355S-6	160	220	291	277	267	990	94,8	0,88	1543	1,9	2	6,7	1610
YB-355M1-6	185	250	336	321	310	990	95	0,88	1785	1,9	2	6,7	1750
YB-355M2-6	200	270	363	345	333	990	95	0,88	1929	1,9	2	6,7	1770
YB-355L1-6	220	300	401	381	367	990	95	0,88	2122	1,9	2	6,7	1800
YB-355L2-6	250	340	454	432	416	990	95	0,88	2411	1,9	2	6,7	1850

TECHNICAL DATA (50HZ)

Frame	Output (kW)		Rated Current			Speed r/min	Eff % η	Power Factor	Rated Torque	Locked Rotor	Max. Torque	Locked Rotor	Weight
	kW	HP	380V	400V	415V				T _n (Nm)	T _{st} / T _n	T _{max} / T _n	T _{st} / I _n	
Synchronous Speed 750 rpm													
YB-80M1-8	0,18	0,25	0,88	0,84	0,8	650	51	0,61	2,6	1,8	1,9	3,3	20
YB-80M2-8	0,25	0,37	1,15	1,1	1,06	650	54	0,61	3,7	1,8	1,9	3,3	22
YB-90S-8	0,37	0,5	1,49	1,41	1,36	660	62	0,61	5,4	1,8	1,9	4	28
YB-90L-8	0,55	0,75	2,17	2,07	1,99	660	63	0,61	8	1,8	2	4	30
YB-100L1-8	0,75	1	2,4	2,28	2,19	690	71	0,67	10,4	1,8	2	4	40
YB-100L2-8	1,1	1,5	3,32	3,15	3,04	700	73	0,69	15,2	1,8	2	5	46
YB-112M-8	1,5	2,2	4,4	4,18	4,03	710	75	0,69	20,5	1,8	2	5	57
YB-132S-8	2,2	3	6,04	5,73	5,53	710	78	0,71	29,6	1,8	2	6	83
YB-132M-8	3	4	7,9	7,51	7,24	720	79	0,73	40,4	1,8	2	6	95
YB-160M1-8	4	5,5	10,3	9,8	9,4	720	81	0,73	53,1	1,9	2	6	158
YB-160M2-8	5,5	7,5	13,6	12,9	12,5	720	83	0,74	73	2	2	6	180
YB-160L-8	7,5	10	17,8	16,9	16,3	720	85,5	0,75	99,5	2	2	6	181
YB-180L-8	11	15	25,1	23,9	23	730	87,5	0,76	144	2	2	6,6	228
YB-200L-8	15	20	34,1	32,4	31,2	730	88	0,76	196	2	2	6,6	335
YB-225S-8	18,5	25	41,1	39	37,6	730	90	0,76	242	1,9	2	6,6	371
YB-225M-8	22	30	47,4	45	43,3	730	90,5	0,78	288	1,9	2	6,6	398
YB-250M-8	30	40	63,4	60,2	58,1	735	91	0,79	390	1,9	2	6,6	522
YB-280S-8	37	50	77,8	73,9	71,2	735	91,5	0,79	481	1,9	2	6,6	626
YB-280M-8	45	60	94,1	89,4	86,1	735	92	0,79	585	1,9	2	6,6	722
YB-315S-8	55	75	111	106	102	735	92,8	0,81	715	1,8	2	6,6	955
YB-315M-8	75	100	151	144	139	735	93	0,81	975	1,8	2	6,6	1160
YB-315L1-8	90	120	178	169	163	740	93,8	0,82	1162	1,8	2	6,6	1238
YB-315L2-8	110	150	217	206	199	740	94	0,82	1420	1,8	2	6,4	1362
YB-355S-8	132	180	261	248	239	740	94	0,82	1704	1,8	2	6,4	1620
YB-355M-8	160	220	315	299	288	740	94,2	0,82	2065	1,8	2	6,4	1710
YB-355L1-8	185	250	362	344	332	740	94,5	0,82	2388	1,8	2	6,4	1900
YB-355L2-8	200	270	387	368	355	740	94,5	0,82	2581	1,8	2	6,4	2000
Synchronous Speed 600 rpm													
YB-315S-10	45	60	99,6	94,7	91,2	590	91	0,75	728	1,5	2	6,4	1042
YB-315M-10	75	75	121	115	111	590	92	0,75	890	1,5	2	6,4	1157
YB-315L1-10	75	100	162	154	148	590	92,5	0,76	1214	1,5	2	6,4	1310
YB-315L2-10	90	120	191	181	175	590	93	0,77	1457	1,3	2	6,4	1385
YB-315M1-10	110	150	230	218	211	590	93,2	0,78	1781	1,3	2	6,4	1500
YB-315M2-10	132	180	275	261	252	590	93,5	0,78	2137	1,3	2	6,4	1600
YB-355L1-10	160	220	333	317	305	590	93,5	0,78	2590	1,3	2	6,4	1700
YB-355L2-10	185	250	385	366	353	590	93,5	0,78	2995	1,3	2	6,4	1800

Safe and efficient motor solution providers and manufactures.

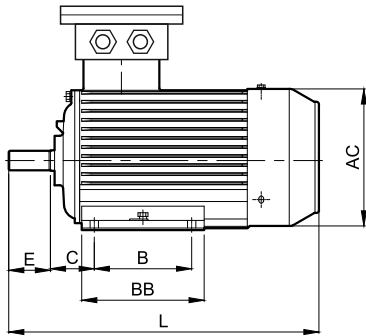

H80-132

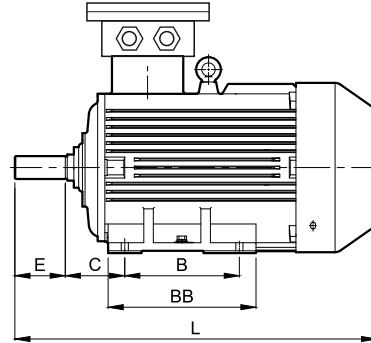
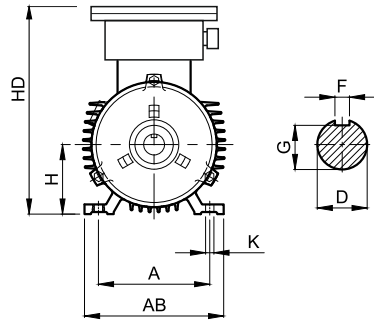

H160-355

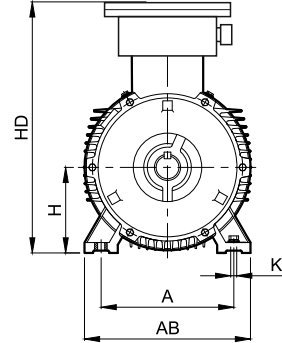

Mounting and overall dimensions
Frame with foundation, cover without flange (B3)

Frame	Pole	Mounting-Dimension									Over All-Dimension					
		A	B	C	D	E	F	G	H	K	AB	AC	BB	HD	L	
80M	2-8	125	100	50	19	40	6	15,5	80	10	165	165	130	320	330	
90S	2-8	140		56	24	50	8	20	90		180	180				155
90L	2-8	140	125	56	24	50		8	20	90	12	200	205	176	400	440
100L	2-8	160	63	28	60	24	100		112	245		230	180			
112M	2-8	190	140	70	28	60	10	33	132	15	280	270	190	450	510	
132S	2-8	216	89	38	80	10		33	132		230	270				230
132M	2-8	216	178	89	38	80	10	33	132	15	280	270	190	450	510	
160M	2-8	254	210	108	42	110		12	37		160	330				325
160L	2-8	254	254	108	42		110	12	37	160	15	330	325	302	520	710
180M	2-8	279	241	121	48	110		14	42,5	180		19	355	360	311	550
180L	2-8	279	279	121	48		110	14	42,5	180	19		355	360	349	550
200L	2-8	318	305	133	55	110		16	49	200		19	390	400	366	645
225S	4-8	356	286	149	60		140	18	53	225	19		435	450	355	690
225M	2	356	311	149	55	110	16	49	225	19		435	450	380	690	860
225M	4-8	356	311	149	55	110	16	49	225		19	435	450	380	690	890
250M	2	406	349	168	60	140	18	53	250	24		490	500	420	730	945
250M	4-8	406	349	168	60		140	18	53		250	24	490	500	420	730
280S	2	457	368	190	65	140		20	67,5	280	24		545	560	438	810
280S	4-8				75		438									
280M	2	457	419	190	65	140	18	58	280	24	545	560	493	810	1060	
280M	4-8				75		493									
315S	2	508	406	216	65	140	18	58	315	28	640	630	550	1020	1320	
315S	4-10				80		550									
315M	2	508	457	216	65	140	18	58	315	28	640	630	680	1020	1350	
315M	4-10				80		680									
315L	2	508	508	216	65	140	18	58	315	28	640	630	680	1020	1490	
315L	4-10				80		680									
355S	2	610	500	254	75	140	20	67,5	355	28	740	750	636	1080	1570	
355S	4-10				95		636									
355M	2	610	560	254	75	140	20	67,5	355	28	740	750	696	1080	1650	
355M	4-10				95		696									
355L	2	610	630	254	75	140	20	67,5	355	28	740	750	766	1080	1750	
355L	4-10				95		766									

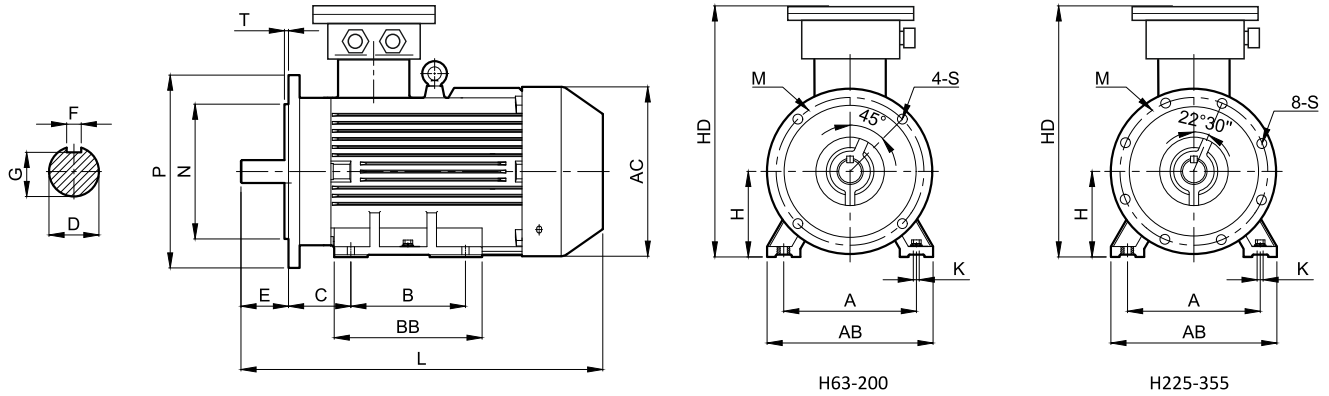

Mounting and overall dimensions
Frame with feet, end-shield with flange (with through holes) (B35)

Frame	Pole	Mounting-Dimension													Flange Holes	Over All Dimension					
		A	B	C	D	E	F	G	H	K	M	N	P	T		AB	AC	AD	BB	HD	L
80M	2-8	125	100	50	19	40	6	15,5	80	10	165	130	200	4	165	165	180	130	320	330	
90S	2-8	140		56	24	50	8	20	90						130	350		360			
90L	2-8	140	125	63	28	60		24	100	12	215	180	250	12	180	180	200	155	400	385	
100L	2-8	160	70				10								33	132		265	230	300	176
112M	2-8	190	140	89	38	80	10	37	160	15	300	250	15	245	230	220	180	420	460		
132S	2-8	216	178											12	37		160	265	230	300	190
132M	2-8	216	210	108	42	110	14	42,5	180	19	350	300	19	280	270	200	230	450	550		
160M	2-8	254	254											12	37		160	265	230	300	190
160L	2-8	254	210	108	42	110	14	42,5	180	15	300	250	15	330	325	220	302	520	670		
180M	2-8	279	241											12	37		160	330	325	220	311
180L	2-8	279	279	121	48	110	16	49	200	19	350	300	19	355	360	200	349	550	750		
200L	2-8	318	305											133	55		16	49	200	350	300
225S	4-8	356	286	149	60	140	18	53	225	19	400	350	450	4	435	450	250	355	690	865	
225M	2		311		55	110	16	49										225		400	350
225M	4-8	311	60	140	18	53	18	58	250	24	500	450	550	0	490	500	300	380	730	890	
250M	2	406	349															168		65	18
280S	2	457	368	190	75	140	20	67,5	280	24	500	450	550	0	545	560	300	438	810	1010	
280M	4-8																	419		65	18
280M	2	457	368	190	75	140	20	67,5	280	24	500	450	550	0	545	560	300	493	810	1060	
315S	4-8																	419		65	18
315S	2	508	406	216	80	170	22	71	315	28	600	550	660	8	640	630	400	550	1020	1320	
315M	4-10																	457		80	170
315M	2	508	457	216	65	140	18	58	315	28	740	680	800	8	640	630	400	680	1020	1380	
315L	4-10																	508		65	140
315L	2	508	406	216	80	170	22	71	315	28	600	550	660	8	640	630	400	680	1020	1520	
355S	4-10																	500		75	140
355S	2	610	500	254	95	170	25	86	355	28	740	680	800	8	740	750	500	636	1080	1570	
355M	4-10																	560		75	140
355M	2	610	560	254	95	170	25	86	355	28	740	680	800	8	740	750	500	696	1080	1650	
355L	4-10																	630		95	170
355L	2	610	560	254	75	140	20	67,5	355	28	740	680	800	8	740	750	500	766	1080	1750	
355L	4-10																	630		75	140

Safe and efficient motor solution providers and manufactures.

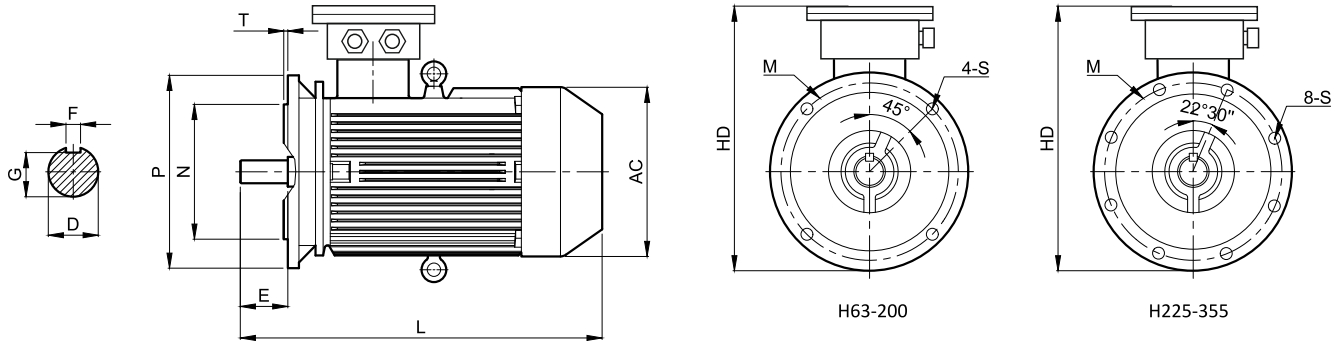

Mounting and overall dimensions
Frame without feet, end-shield with flange (B5)

Frame	Pole	Mounting Dimension									Flange Holes	Over All Dimension		
		D	E	F	G	M	N	P	S	T		AC	AD	L
80M	2-8	19	40	6	15,5	165	130	200	12	3,5	4	165	180	330
90S	2-8	24	50	20	360									
90L	2-8	28	60	8	24	215	180	250	15	4		180	200	385
100L	2-8											205		
112M	2-8	38	80	10	33	265	230	300	19	5	230	220	460	
132S	2-8										270			510
132M	2-8	42	110	12	37	300	250	350	19	5	270	220	550	
160M	2-8										325			670
160L	2-8	48	110	14	42,5	300	250	350	19	5	325	220	710	
180M	2-8										360			730
180L	2-8	55	110	16	49	350	300	400	19	5	360	250	750	
200L	2-8										400			805
225S	4-8	60	140	18	53	400	350	450	19	5	400	250	865	
225M	2	55	110	16	49						400			350
		4-8	60			53								

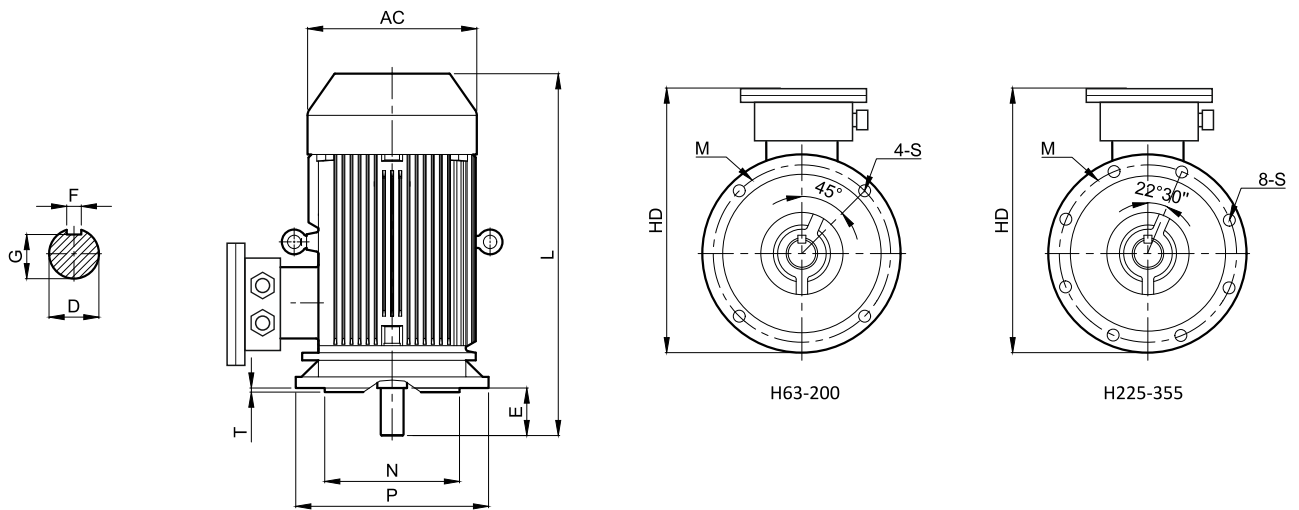

Mounting and overall dimensions
Frame without feet, end-shield with flange (V1)

Frame	Pole	Mounting-Dimension									Flange Holes	Over All Dimension				
		D	E	F	G	M	N	P	S	T		AC	AD	L		
80M	2-8	19	40	6	15,5	165	130	200	12	3,5	4	165	180	330		
90S	2-8	24	50	8	20							360				
90L	2-8	28	60		24	215	180	250	15	4		385				
100L	2-8			205	440											
112M	2-8	38	80	10	33	265	230	300	15	4		230	200	460		
132S	2-8											270		510		
132M	2-8	42	110	12	37	300	250	350	15	4		270	220	550		
160M	2-8											325		670		
160L	2-8	48	110	14	42,5	300	250	350	15	4		325	220	710		
180M	2-8											360		730		
180L	2-8	55	110	16	49	350	300	400	15	4	360	220	750			
200L	2-8										400		805			
225S	4-8	60	140	18	53	400	350	450	19	5	8	400	250	865		
225M	2	55	110	16	49							860				
250M	4-8	60	140	18	53	400	350	450	19	5		450	250	890		
	2											53		945		
280S	4-8	65	140	18	58	500	450	550	19	5		8	500	300	1010	
	2												58			945
280M	4-8	75	140	20	67,5	500	450	550	19	5			560	300	1010	
	2												67,5			1060
315S	4-8	65	140	18	58	600	550	660	24	6			8	600	400	1320
	2													58		1350
315M	4-10	80	170	22	71	600	550	660	24	6	630			400	1380	
	2										71				1490	
315L	4-10	80	170	22	71	600	550	660	24	6	630			400	1520	
	2										71				1570	
355S	4-10	75	140	20	67,5	740	680	800	24	6	8	740		500	1650	
	2											67,5			1750	
355M	4-10	95	170	25	86	740	680	800	24	6		750		500	1650	
	2											86			1750	
355L	4-10	95	170	25	86	740	680	800	24	6		750	500	1750		
	2											86		1750		

PetropompSad



TÜRKİYE / KONYA
www.petropomsad.com

+90 532 151 25 83

petropomsad@gmail.com
2. ASPAK SANAYİ KARATAY

+90 555 148 89 02